

1/4" GEN2 Variable Pilot Valve Product Line

REV	DATE	DESCRIPTION	ORIGIN (issued by)	APPROVED
001	06/21/2018	Document No: 150-062118-001	AP	SS
002	11-14-2019	Update Table 1	AP	SS
003	11-06-2020	Update to Template	SD	GM

COMPANY PROPRIETARY INFORMATION

Gilmore Technologies, LLC and/or its affiliates (Gilmore). All rights reserved. Gilmore™, Gilmore & Design (Stallion) are registered trademarks or trademarks of Gilmore. This notice and the information contained herein is not to be, in whole or in part, reproduced or transmitted in any form by any means without the express permission of Gilmore. **DISCLAIMER:** Whilst Gilmore has carefully reviewed the contents of this notice and believes the information to be correct, Gilmore does not assume any liability in connection with any use of or reliance upon this information and gives no representation or warranty, express or implied, in respect of the information or any products described herein. This notice is intended for use by persons having suitable technical expertise and skill, at their own discretion and risk. Gilmore may change the information contained herein at any time without notice.

For more information:

Call (713) 468 8778

Info@gilmore.com

Gilmore
1231 Lumpkin Road
Houston, TX 77043

1/4" GEN2 Variable Pilot Valve Product Line

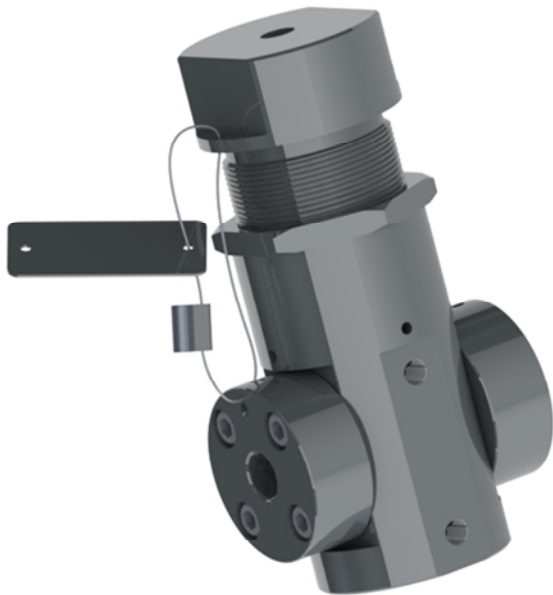

Gilmore announces the new 1/4" GEN2 Variable Pilot Valve product line used to enable accurate and adjustable sequencing of hydraulically controlled DCVs in drilling or production control systems. The Variable Pilot Valve will pressurize or vent a pilot, actuator, or cylinder at a specified pilot pressure, and subsequently reset with low dead band. With an identical footprint as the legacy Variable Pilot Valve, the new product line is a drop-in replacement. The 1/4" GEN2 Variable Pilot Valve is field repairable.

Features and Benefits:

- Extrusion proof Tungsten Carbide seat design
- CRA spring housing materials with integral adjustment stop
- Low dead band operation
- Wire tag provided for security
- Provision for panel mounting
- T316 body and flange material
- Separately piloted version also available

Figure 1. PN 29045: 1/4" NPT Variable Pilot Valve, 800-1600 psi Set Point, Combined Pilot

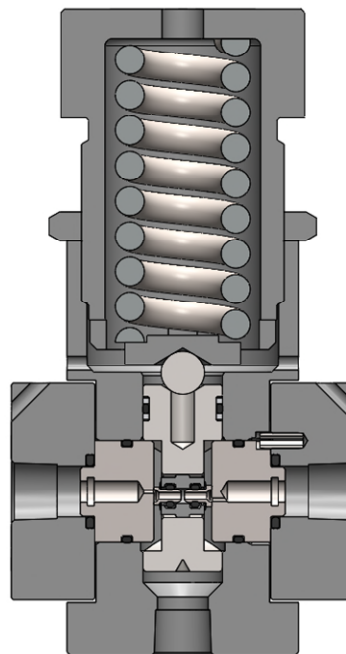



Gilmore has exceeded API 16D requirements by qualifying the 1/4" Variable Pilot Valve designs with multiple endurance qualification tests to 2500 cycles at maximum flow conditions to mimic customer applications.

Please note that sales of all legacy 1/4" Variable Pilot Valve part numbers listed below will be discontinued June 21st, 2019, as a result of the new Gilmore 1/4" Variable Pilot Valve product line availability. The new Gilmore 1/4" Variable Pilot Valves are now available for purchase as drop-in replacements for the legacy 1/4" Variable Pilot Valves.

Gilmore will continue to support legacy 1/4" Variable Pilot Valves after they are discontinued:

- Gilmore will continue providing repair kits and seal kits in support of discontinued 1/4" Variable Pilot Valves.
- Gilmore Aftermarket will continue to support discontinued legacy products with factory failure analysis and repair services.

Table 1. Legacy and New 1/4" Variable Pilot Valve Part Numbers:

Item	Legacy Valve Description	Legacy Valve PN	Legacy Repair Kit PN	New Valve Description	New Valve PN	New Repair Kit PN
1	Valve, Variable Pilot, 1/4" NPT, N.C., Stop Ring, Combined Pilot, Set Point Range 800-1600 psi	25005-1	25005-1 RK	Valve, Variable Pilot, 1/4" NPT, N.C., Combined Pilot, Set Point Range 800-1600 psi	29045	29045 RK
2	Valve, Variable Pilot, 1/4" NPT, N.C., Stop Ring, Combined Pilot, Set Point Range 1600-3300 psi	25005-2	25005-2 RK	Valve, Variable Pilot, 1/4" NPT, N.C., Combined Pilot, Set Point Range 1600-3300 psi	29046	29046 RK
3	Valve, Variable Pilot, 1/4" NPT, N.C., Stop Ring, Combined Pilot, Set Point Range 1600-3300 psi	25005-4	25005-4 RK	Valve, Variable Pilot, 1/4" NPT, N.C., Combined Pilot, Set Point Range 1600-3300 psi	29046	29046 RK
4	Valve, Variable Pilot, 1/4" SAE, N.C., Stop Ring, Combined Pilot, Set Point Range 1600-3300 psi	25014	25014 RK	Valve, Variable Pilot, 1/4" SAE, N.C., Combined Pilot, Set Point Range 1600-3300 psi	29051	29051 RK
5	Valve, Variable Pilot, 1/4" SAE, N.C., Bronze Cap, Stop Ring, Combined Pilot, Set Point Range 1600-3300 psi	25014-1	25014 RK	Valve, Variable Pilot, 1/4" SAE, N.C., Combined Pilot, Set Point Range 1600-3300 psi	29051	29051 RK
6	Valve, Variable Pilot, 1/4" SAE x 1/2" SAE, N.C., High Drag, Stop Ring, Separate Pilot, Max Set Point 2600 psi	25015-0.1	25015-0.1 RK	Valve, Variable Pilot, 1/4" SAE x 1/2" SAE, N.C., High Drag, Separate Pilot, Set Point Range 1600-3300 psi	29047	29047 RK
7	Valve, Variable Pilot, 1/4" SAE x 1/2" SAE, N.O., Separate Pilot, Max Set Point 2600 psi	25018	25018 RK	Valve, Variable Pilot, 1/4" SAE x 1/2" SAE, N.O., Separate Pilot, Set Point Range 1600-3300 psi	29050	29050 RK
8	Valve, Variable Pilot, 1/4" SAE x 1/2" SAE, N.C., High Drag, Stop Ring, Separate Pilot, Max Set Point 1200 psi	28315	28315 RK	Valve, Variable Pilot, 1/4" SAE x 1/2" SAE, N.C., High Drag, Separate Pilot, Set Point Range 800-1600 psi	29084	29084 RK
9	N/A	N/A	N/A	Valve, Variable Pilot, 1/4" SAE x 1/2" SAE, N.C., High Drag, Separate Pilot, Elgiloy Spring Set Point Range 1600-3300 psi	29047-1	29047-1 RK

10	N/A	N/A	N/A	Valve, Variable Pilot, 1/4" NPT, N.O., Combined Pilot, Set Point Range 800-1600 psi	29048	29048 RK
11	N/A	N/A	N/A	Valve, Variable Pilot, 1/4" NPT, N.O., Combined Pilot, Set Point Range 1600-3300 psi	29049	29049 RK
12	N/A	N/A	N/A	Valve, Variable Pilot, 1/4" SAE, N.C., Separate Pilot, Set Point Range 1600-3300 psi	29052	29052 RK
13	Valve, Variable Pilot, 1/4" SAE x 1/2" SAE, N.C., Separate Pilot, Max Set Point 2600 psi	25015	25015-RK	Valve, Variable Pilot, NC, 3 Way, Combined Pilot, 1/4" SAE In, 1/4" SAE Out, 800-1600 PSI	29125	29125 RK

The following legacy 1/4" Variable Pilot Valves will be discontinued June 21st, 2019. If a new 1/4" Variable Pilot Valve part number is not listed below for a specific legacy part number, please contact Gilmore Customer Service to request a quotation for a new part number.

Table 2. Legacy Variable Pilot Valve Part Numbers

Item	Legacy Description	Legacy Valve PN	Legacy Repair Kit PN	New Valve Description	New Valve PN	New Repair Kit PN
1	Valve, Variable Pilot, 1/4" SAE x 1/4" NPT, N.O., Separate Pilot, Set Point Range 5000-10000 psi	25017	25017 RK	N/A	N/A	N/A
2	Valve, Variable Pilot, 1/4" SAE x 1/4" NPT, N.C., Separate Pilot, Set Point Range 5000-10000 psi	25027	25027 RK	N/A	N/A	N/A

Please contact Gilmore Customer Service to request drawings and quotations for these Variable Pilot Valves at info@gilmore.com.