

1" GEN2 10 ksi Damping Pressure Regulator

REV	DATE	DESCRIPTION	ORIGIN (issued by)	APPROVED
REV 001	06/15/23	Document No: 135-061523-001	AJP	BR

COMPANY PROPRIETARY INFORMATION

© Gilmore Valve, LLC and/or its affiliates (Gilmore). All rights reserved Gilmore™, Gilmore & Design (Stallion) are registered trademarks or trademarks of Gilmore. This notice and the information contained herein is not to be, in whole or in part, reproduced or transmitted in any form by any means without the express permission of Gilmore. **DISCLAIMER:** Whilst Gilmore has carefully reviewed the contents of this notice and believes the information to be correct, Gilmore does not assume any liability in connection with any use of or reliance upon this information and gives no representation or warranty, express or implied, in respect of the information or any products described herein. This notice is intended for use by persons having suitable technical expertise and skill, at their own discretion and risk. Gilmore may change the information contained herein at any time without notice.

For more information:

Call (713) 468-8778

INFO@Gilmore.com

Gilmore
1231 Lumpkin Road
Houston, TX 77043

1" GEN2 10 ksi Damping Pressure Regulator

Gilmore announces the new 1" GEN2 10 ksi Damping Pressure Regulator, with manually adjustable spring for critical applications both subsea and topside. Gilmore's proprietary Tungsten Carbide seal trim combined with the patented damped carrier design provides benchmark reliability.

Features and Benefits:

- Qualification exceeds API 16D requirements – 10,000 cycles
- Patented guided hydraulic damping technology:
 - Reduces oscillation, hunting, chattering and vibration
 - Allows for quicker system hydrostatic testing
- Low deadband performance optimizes reaction time
- Tungsten Carbide seal trim for debris tolerance
- Bolted plunger guide for ease of maintenance
- Dynamic Plunger T-Seal
- Improved Valve Materials:
 - 17-4PH 1150D Body & T316 Flanges
 - Nitronic 60 Seal Carrier
 - T316 Spring Housing

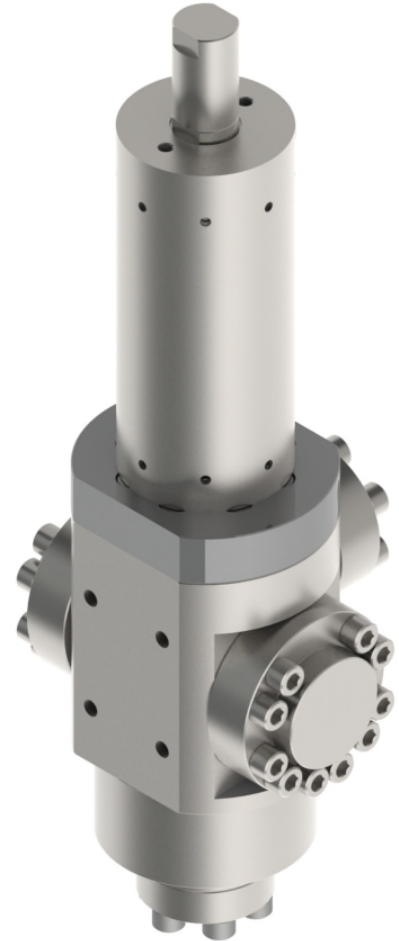

Figure 1. PN 29230: 1" GEN2, Pressure Regulator, 10 ksi, Manual Spring, 3/4" SAE Ports, 5500-3000 psi range

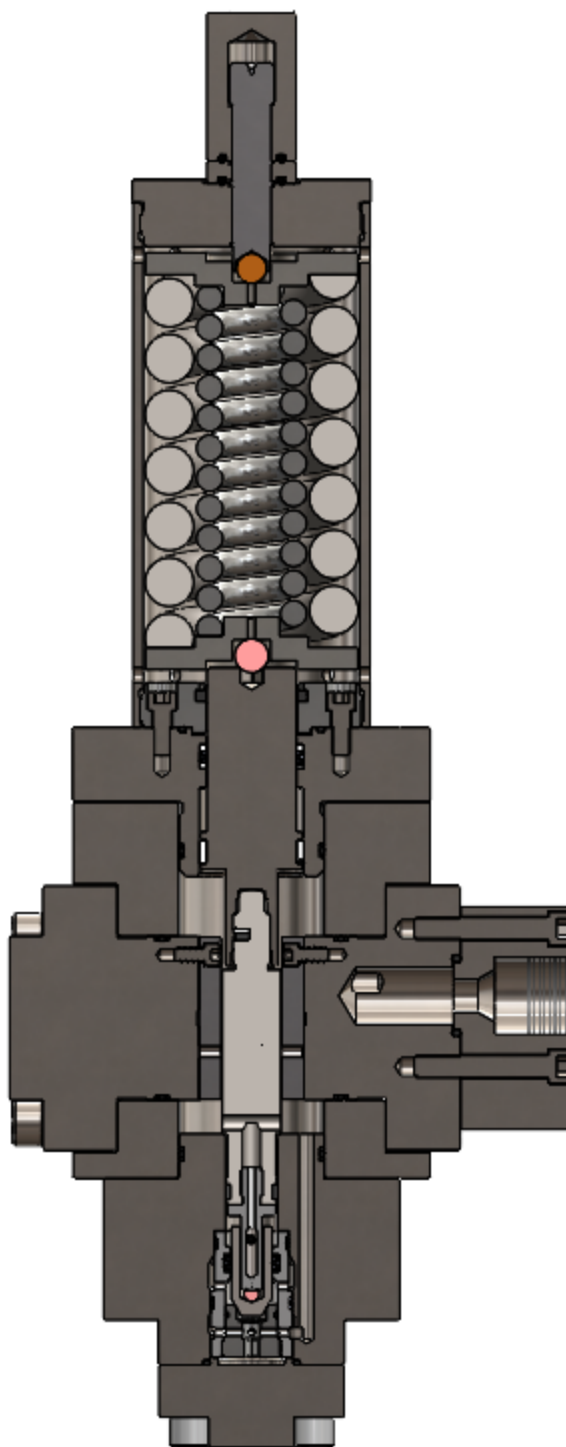

Figure 2. PN 29239: 1" GEN 2, Pressure Regulator, 10 ksi, Manual Spring, 1" MP Ports, 5500-3000 psi range

1" GEN2 10 ksi Damping Pressure Regulator

Gilmore has exceeded API 16D requirements by qualifying the new 1" GEN2 Damping 10 ksi Pressure Regulator designs to two endurance qualification tests of 10,000 cycles, at a maximum flow rate of 85 gpm at 10,000 psi, single inlet, with 1% - 4% water glycol test fluid.

Table 1. New 1" GEN2 Damping Pressure Regulator:

Item	New Valve Description	New Valve PN	New Repair Kit PN
1	1" GEN2 Regulator, Damping, 10 ksi, Manual, ¾" SAE, Single Inlet, 5500-3000 psi range	29230	29230 RK
2	1" GEN2 Regulator, Damping, 10 ksi, Manual, ¾" SAE, Single Inlet, 3500-2000 psi range	29231	29231 RK
3	1" GEN2 Regulator, Damping, 10 ksi, Manual, 1" MP Ports, Single Inlet, 3500-2000 psi range	29238	29238 RK
4	1" GEN2, Regulator, Damping, 10 ksi, Manual, 1" MP Ports, Single Inlet, 5500-3000 psi range	29239	29239 RK
5	1" GEN2, Regulator, Damping, 10 ksi, Manual, 1" MP Ports, Dual Inlet, 5500-3000 psi range	29240	29240 RK

The new product family of 1" GEN2 10 ksi Damping Pressure Regulator designs is now available. Specific customer requirements for different actuators or connection types will be accommodated. Please contact Gilmore Customer Service to request additional drawings and quotations for these new 1" GEN2 10ksi Damping Pressure Regulators at Info@gilmore.com.