



Product Information Bulletin (PIB)

1" GEN2 Pressure Regulator, Compensator Option

REV	DATE	DESCRIPTION	ORIGIN (issued by)	APPROVED
A	03/30/21	Document No: 135-033021-001	AP	GM

**COMPANY PROPRIETARY INFORMATION**

Gilmore Technologies, LLC and/or its affiliates (Gilmore). All rights reserved. Gilmore™, Gilmore & Design (Stallion) are registered trademarks or trademarks of Gilmore. This notice and the information contained herein is not to be, in whole or in part, reproduced or transmitted in any form by any means without the express permission of Gilmore. **DISCLAIMER:** Whilst Gilmore has carefully reviewed the contents of this notice and believes the information to be correct, Gilmore does not assume any liability in connection with any use of or reliance upon this information and gives no representation or warranty, express or implied, in respect of the information or any products described herein. This notice is intended for use by persons having suitable technical expertise and skill, at their own discretion and risk. Gilmore may change the information contained herein at any time without notice.

---

**For more information:**

Call (713) 468 8778  
info@gilmore.com

Gilmore  
1231 Lumpkin Road  
Houston, TX 77043

## 1" GEN2 Pressure Regulator, Compensator Option

Gilmore announces the availability of a new Pressure Compensator option for the 1" GEN 2 Pressure Regulator for critical subsea applications. The Tungsten Carbide Seated GEN 2 Pressure Regulator, Air Motor has been designed with the same footprint as the legacy Pressure Regulators. This thoroughly redesigned product offering provides an order of magnitude improvement in cycle life.

### Features and Benefits:

- Qualification exceeds API 16D requirements – 10,000 cycles at full flow rates and pressures
- Fully enclosed Spring Chamber
- Additional connection port
- Failsafe adjustment maintains set point hydraulic pressure indifferent of pneumatic pressure loss
- Proprietary guided hydraulic damping technology
- Improved deadband performance
- Enhanced bolted plunger guide
- Upgraded dynamic plunger T-Seal
- Threaded seal carrier alignment
- CRA Material Construction
  - Refined Tungsten Carbide seal trim
  - Nitronic 60 Plunger and Seal Carrier
  - T316 Spring Housing
- Patent #10,739,796



Figure 1. PN 29094: 1" Gen 2 Pressure Regulator, Manual Spring, Double Inlet, Code 62, 4500 – 2000 psi with Optional Pressure Compensator



## Product Information Bulletin (PIB)

### 1" GEN2 Pressure Regulator, Compensator Option

Gilmore has exceeded API 16D requirements by qualifying the new 1" GEN 2 Manual Regulator designs to 10,000 cycles, at a starting flow rate of 125 gpm per inlet, at 5000 psi, with 1% - 4% water glycol test fluid. Hyperbaric testing was performed based on API 17D.

The new Gilmore 1" GEN 2 Pressure Regulators have an identical flow port footprint to the legacy regulators. They are now available to purchase with a Pressure Compensator installed onto spring housing. One example of a typical assembly configuration is listed below for reference. Gilmore will create other customized 1" Gen 2 Pressure Regulators to add the Pressure Compensator option to configurations that are required.

Please contact Gilmore Customer Service to request a quotation for the 1" GEN 2 Pressure Regulator listed below, or other custom configurations as required.

**Table 1. Examples of New 1" GEN 2 Pressure Regulators with Compensator Option:**

Item	New Valve Description	Legacy PN Reference	New Valve PN	New Repair Kit PN	New Seal Kit PN
1	Valve, Pressure Regulator, Gen 2, Air Motor, 1500-3500 psi range, SAE Ports, Double Inlet	N/A	29094	29094 RK	29094 SK

## 1" GEN2 Pressure Regulator, Compensator Option

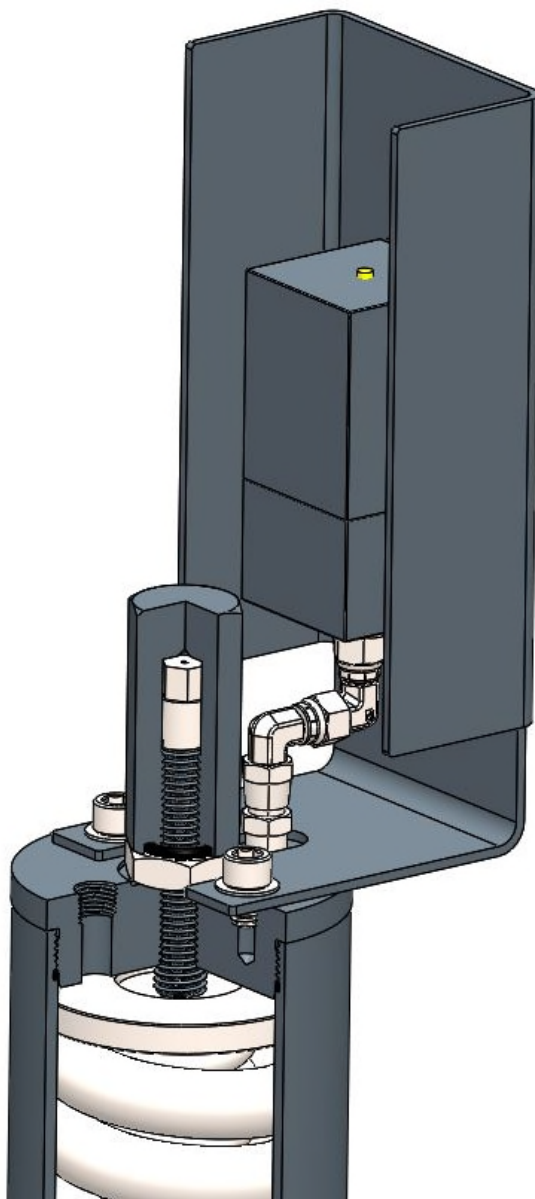

Figure 2. PN 29094 1" Gen 2 Pressure Regulator, Manual Spring, Detailed sealed spring chamber.

Please contact Gilmore Customer Service to request any drawings, manuals and quotations for these new GEN 2 Manual Regulators at [info@gilmore.com](mailto:info@gilmore.com).