

1/2" MKIV Shuttle Valve Product Line

REV	DATE	DESCRIPTION	ORIGIN (issued by)	APPROVED
Rev A	08-10-2018	Document No: 120-081018-001	AP	SS

COMPANY PROPRIETARY INFORMATION

Gilmore Technologies, LLC and/or its affiliates (Gilmore). All rights reserved. Gilmore™, Gilmore & Design (Stallion) are registered trademarks or trademarks of Gilmore. This notice and the information contained herein is not to be, in whole or in part, reproduced or transmitted in any form by any means without the express permission of Gilmore. **DISCLAIMER:** Whilst Gilmore has carefully reviewed the contents of this notice and believes the information to be correct, Gilmore does not assume any liability in connection with any use of or reliance upon this information and gives no representation or warranty, express or implied, in respect of the information or any products described herein. This notice is intended for use by persons having suitable technical expertise and skill, at their own discretion and risk. Gilmore may change the information contained herein at any time without notice.

For more information:

Call (713) 468 8778
info@gilmore.com

Gilmore
 1231 Lumpkin Road
 Houston, TX 77043

1/2" MKIV Shuttle Valve Product Line

Proserv announces the new Gilmore 1/2" Mark IV Shuttle Valve product line for critical offshore and subsea applications. The 1/2" Mark IV Shuttle Valve product line establishes a new benchmark for reliability and serviceability in drilling control systems where redundant hydraulic pressure supplies are required.

Features and Benefits:

- Qualification exceeds API 16D requirements
 - Non Biased shuttle valves qualified to 2500 cycles at maximum flow conditions
 - Pressure and Spring Biased shuttle valves qualified to 1000 cycles at maximum flow conditions
- Shuttle metal seat no longer requires coining, simplifying on-site repairs
- All shuttle styles are hydraulically dampened
- Common stacked bodies can be readily reconfigured
- Fully serviceable shuttles and body seats can be completely redressed inline.
- Available configurations include Pressure biased, Spring biased, high interflow, low interflow, high drag, low drag options with customizable end connections and mounting provisions.
- Customizable single valve and stack valve assemblies available to suit application requirements
- Suitable for panel mounting or direct mounting
- U.S. Patent 9,915,275

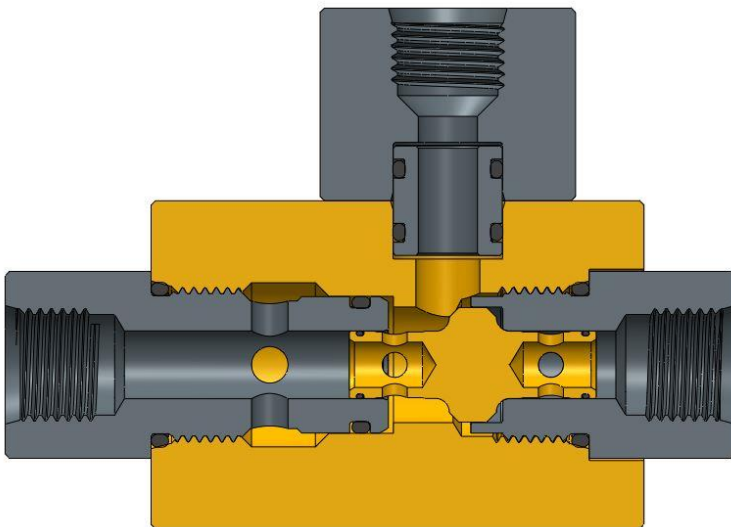

Figure 1. PN 29025: 1/2" MKIV Shuttle Valve, Inline, SAE, Low Interflow, High Drag

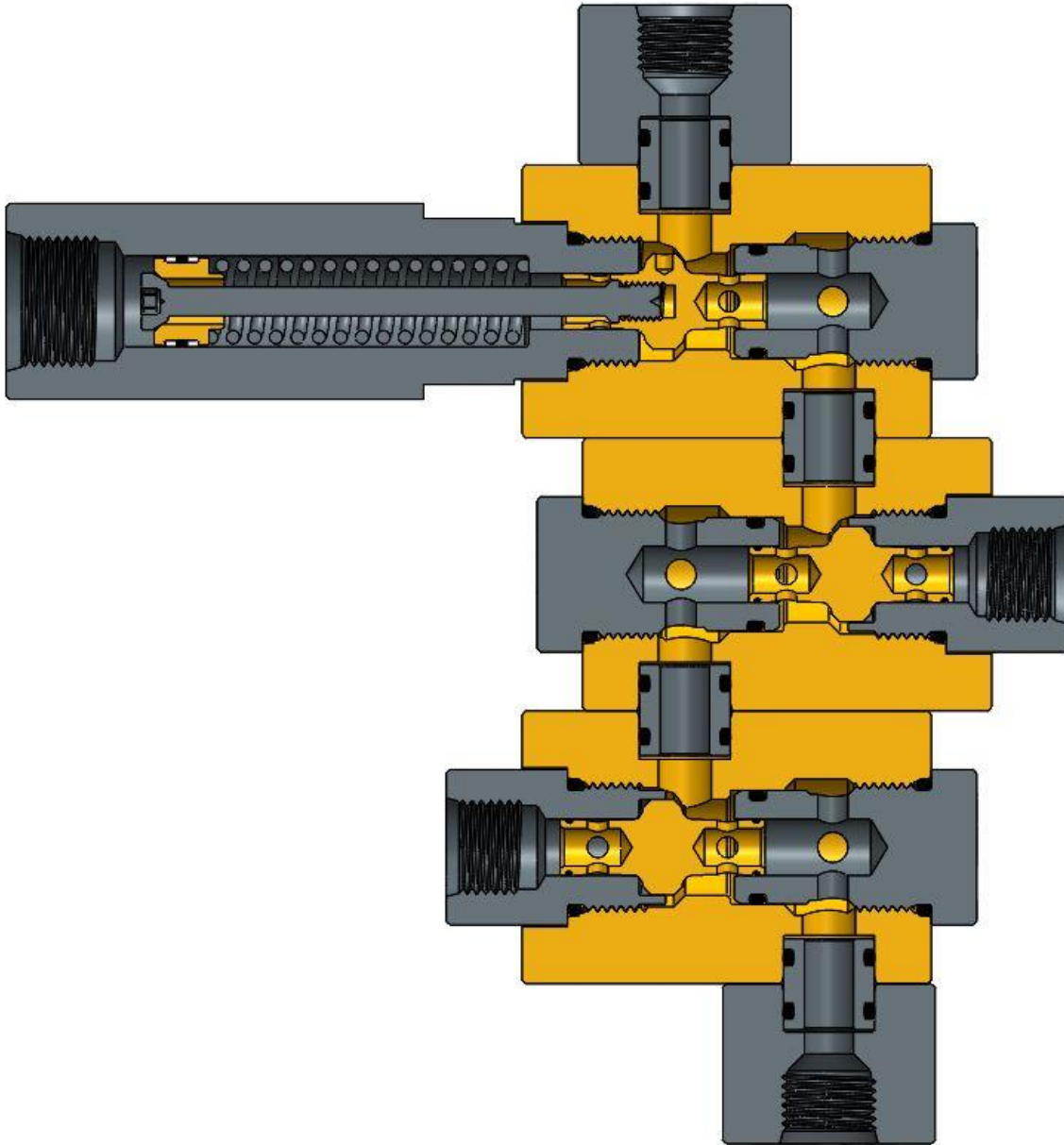

Figure 2. PN 29038: 1/2" MKIV Shuttle Valve, Stack, 4 Inlets, SAE, Pressure Biased, Low Interflow, High Drag

Proserv has exceeded API 16D requirements by qualifying the new 1/2" MKIV Shuttle Valve non-biased designs to multiple endurance qualification tests to 2500 cycles, at a starting flow rate of 45 gpm – and biased designs to 1000 cycles and 40 gpm – at 5000 psi, with 1% - 4% water glycol test fluid.

The new Proserv Gilmore 1/2" MKIV Shuttle Valves are now available for purchase. A few examples of typical assembly configurations are listed below for reference. Proserv Gilmore will create other customized 1/2" MKIV Shuttle valve configurations that are required.

Please contact Proserv Customer Service to request a quotation for the 1/2" MKIV Shuttle Valves listed below, or other configurations as required.

Table 1. Examples of New 1/2" MKIV Shuttle Valve Part Numbers:

Item	New Valve Description	Legacy PN Reference	New Valve PN	New Repair Kit PN	New Seal Kit PN
1	Valve, MKIV, 1/2" Inline, SAE, Low Interflow, High Drag	27027-0.3	29025	29025 RK	29025 SK
2	Valve, MKIV, 1/2", Stack, 3 Inlets, Code 62, Low Interflow, High Drag	27016-3.3	29026	29026 RK	29026 SK
3	Valve, MKIV, 1/2" Inline, SAE, Pressure Biased, 200 psi Shift	28008-1	29027	29027 RK	29027 SK
4	Valve, MKIV, 1/2", Stack, 3 Inlets, SAE, Pressure Biased, 200 psi Shift, Low Interflow, High Drag	27551-4	29028	29028 RK	29028 SK
5	Valve, MKIV, 1/2", Stack, 4 Inlets, SAE, 2x Pressure Biased, 200 psi Shift, Low Interflow, High Drag	N/A	29029	29029 RK	29029 SK
6	Valve, MKIV, 1/2", Stack, 4 Inlets, SAE, Pressure Biased, 200 psi Shift, Low Interflow, High Drag	N/A	29038	29038 RK	29038 SK
7	Valve, MKIV, 1/2" Inline, SAE, Spring Biased	28141	29053	29053 RK	29053 SK
8	Valve, MKIV, 1/2", Inline, NPT, High Interflow, High Drag	N/A	29055	29055 RK	29055 SK
9	Valve, MKIV, 1/2", Inline, Code 62, Pressure Biased, 200 psi Shift	28055	29056	29056 RK	29056 SK

Please note at this time Proserv will continue to support the legacy 1/2" MKIII Shuttle Valves, which have a different footprint than the new 1/2" MKIV Shuttle Valves.