

1" GEN 2 V-Seal Shuttle Valve

REV	DATE	DESCRIPTION	ORIGIN (issued by)	APPROVED
001	03-21-2018	Document No: 120-032118-001	AP	SS
002	07-24-2019	Document No: 120-032118-002	AP	SS
003	11-01-2019	Document No: 120-032118-003	CM	BR
004	12-16-2020	Document No: 120-032118-004	SD	BR

COMPANY PROPRIETARY INFORMATION

Gilmore Technologies, LLC and/or its affiliates (Gilmore). All rights reserved. Gilmore™, Gilmore & Design (Stallion) are registered trademarks or trademarks of Gilmore. This notice and the information contained herein is not to be, in whole or in part, reproduced or transmitted in any form by any means without the express permission of Gilmore. **DISCLAIMER:** Whilst Gilmore has carefully reviewed the contents of this notice and believes the information to be correct, Gilmore does not assume any liability in connection with any use of or reliance upon this information and gives no representation or warranty, express or implied, in respect of the information or any products described herein. This notice is intended for use by persons having suitable technical expertise and skill, at their own discretion and risk. Gilmore may change the information contained herein at any time without notice.

For more information:

Call (713) 468 8778
info@gilmore.com

Gilmore
1231 Lumpkin Road
Houston, TX 77043

1" GEN 2 V-Seal Shuttle Valve

Gilmore announces the new 1" GEN2 V-Seal Shuttle Valve for critical offshore and subsea applications. The soft-seated 1" GEN2 Shuttle Valve is designed with the same footprint as the legacy Traditional Shuttle Valves for effortless retrofits. Gilmore's new proprietary dynamic V-Seal technology provides an order of magnitude improvement in cycle life.

Features and Benefits:

- Qualification exceeds API 16D requirements
 - Two separate 2500 cycle tests at maximum flow conditions
- New V-Seal and hydraulic dampening technology which does not feather or extrude to improve cycle life
- Corrosion Resistant Materials for subsea applications:
 - T316 Body, Nitronic 60 Shuttle, Sleeve and Cap
 - PEEK Spacer and PTFE/Nitrile 90 Duro V-Seal
 - A286 Cap Screws with 254 SMO Nordlock Washers
- Designed and tested to meet demands of 5 year maintenance free service under normal operating conditions
- Field Repairable
- U.S. Patent 9,719,600



Figure 1. PN 29042: 1" NPT GEN 2 V-Seal Shuttle Valve, 5000 psi, Low interflow

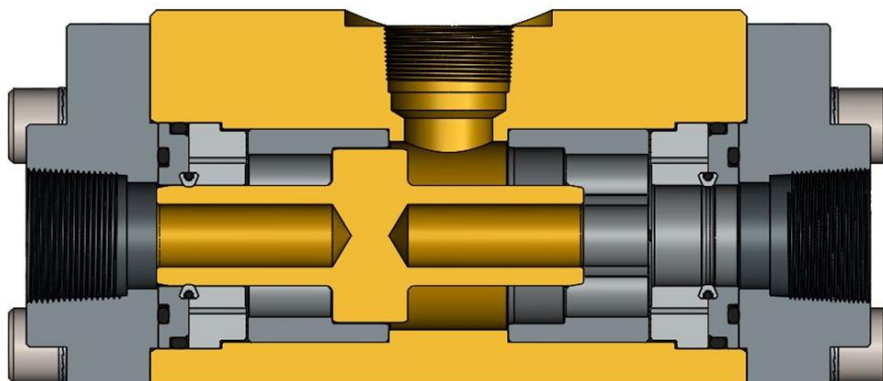
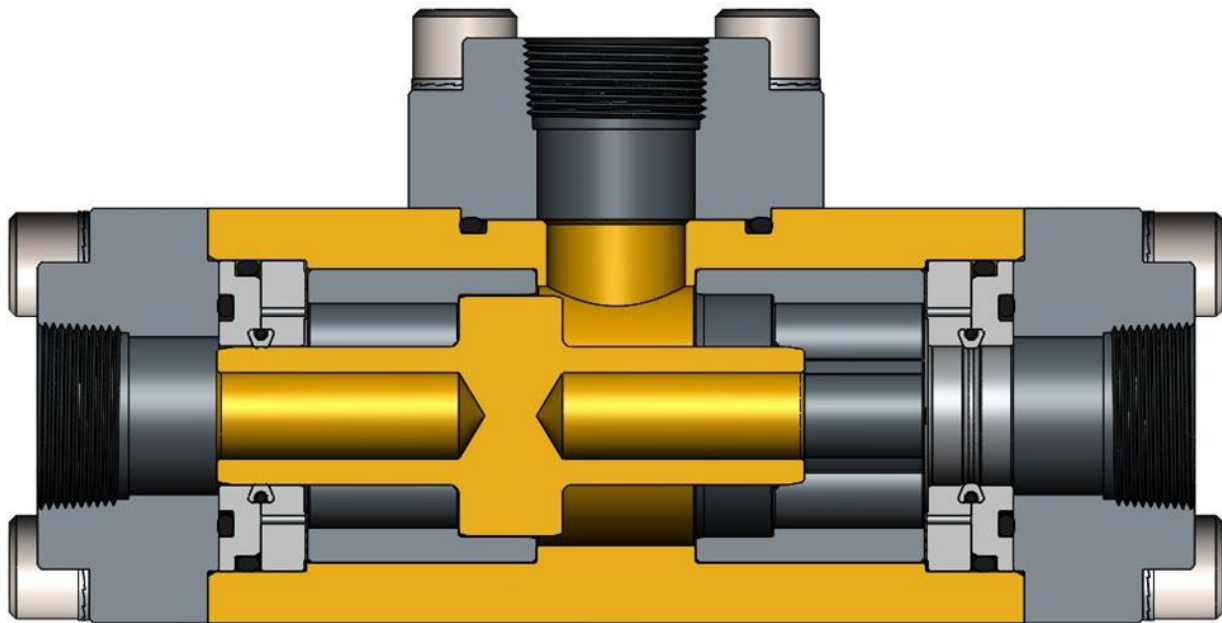

Figure 2. PN 29041: 1" NPT GEN 2 V-Seal Shuttle Valve, 3000 psi, High Interflow



Gilmore has exceeded API 16D requirements by qualifying the new 1" GEN2 V-Seal Shuttle Valve designs to multiple endurance qualification tests to 2500 cycles, at a starting flow rate of 150 gpm at 5000 psi, with 1% - 4% water glycol test fluid.

The new Gilmore 1" GEN2 V-Seal Shuttle Valves have an identical footprint to the legacy valves.

As a result of the new Gilmore 1" GEN2 V-Seal Shuttle Valve product line, please note that sales of the legacy 1" Traditional Shuttle Valve part numbers listed below in Table 1 were discontinued as of March 21, 2019.

The new Gilmore 1" GEN2 V-Seal Shuttle Valve is now available as a replacement for the legacy 1" Traditional Shuttle Valves.

Gilmore will continue to sell and support the legacy 1" shuttle valve repair kits, seal kits and Aftermarket support after new valve sales of the legacy design are discontinued.



Table 1. New and Legacy 1" V-Seal Shuttle Valve Part Numbers:

Item	Legacy Description	Legacy Valve PN	Legacy Repair Kit PN	New Valve Description	New Valve PN	New Repair Kit PN
1	Valve, Shuttle, Traditional, 1" NPT, Low Interflow, 3000 psi	25413	25413 RK	Valve, Shuttle, GEN 2, 1" NPT, Low Interflow, 3000 psi	29043	29043 RK
2	Valve, Shuttle, Traditional, 1" NPT, Low Interflow, 3000 psi, Country of Origin material	25413-1	25413-1 RK	Valve, Shuttle, GEN 2, 1" NPT, Low Interflow, 3000 psi	29043	29043 RK
3	Valve, Shuttle, Traditional, 1" NPT, High Interflow, 3000 psi	25429	25429 RK	Valve, Shuttle, GEN 2, 1" NPT, High Interflow, 3000 psi	29041	29041 RK
4	Valve, Shuttle, Traditional, 1" NPT, High Interflow, 5000 psi	25475	25475 RK	Valve, Shuttle, GEN 2, 1" NPT, High Interflow, 5000 psi	29044	29044 RK
5	Valve, Shuttle, Traditional, 1" NPT, Low Interflow, 5000 psi	25476	25476 RK	Valve, Shuttle, GEN 2, 1" NPT, Low Interflow, 5000 psi	29042	29042 RK
6	Valve, Shuttle, Traditional, 1" NPT, High Interflow, N60 Trim, 5000 psi	115396	115518	Valve, Shuttle, GEN 2, 1" NPT, High Interflow, 5000 psi	29044	29044 RK
7	Valve, Shuttle, Traditional, 1" NPT, Low Interflow, N60 Trim, 5000 psi	139907	140249	Valve, Shuttle, GEN 2, 1" NPT, Low Interflow, 5000 psi	29042	29042 RK
8	Valve, Shuttle, Traditional, 1" SAE, Low Interflow, 3000 psi	25427	25427 RK	Valve, Shuttle, GEN 2, 1" SAE in, 1" SAE Out, Low Interflow, 3000 psi	29070	29070 RK
9	Valve, Shuttle, Traditional, 1" SAE, Low Interflow, 3000 psi, Code 62 Outlet	25802	25802 RK	Valve, Shuttle, GEN 2, 1" SAE in, Special 1" SAE C62 Out, Low Interflow, 3000 psi	29071	29071 RK

The following legacy 1" Traditional Shuttle Valves listed in Table 2 were discontinued March 21, 2019. If a new 1" GEN 2 V-Seal Shuttle Valve part number is needed but not listed for a specific legacy part number, please contact Gilmore Customer Service to request a quotation for a new 1" GEN 2 part number.

Table 2. Legacy Shuttle Valve Part Numbers:

Item	Legacy Description	Legacy Valve PN	Legacy Repair Kit PN	New Valve Description	New Valve PN	New Repair Kit PN
1	Valve, Shuttle, Traditional, 1" Socket Weld, Low Interflow, 5000 psi	28337	28337 RK	N/A	N/A	N/A



Please contact Gilmore Customer Service to request drawings and quotations for these 1" GEN 2 V-Seal Shuttle Valves at Info@gilmore.com.