

1-1/2" GEN2 V-Seal Shuttle Valve

REV	DATE	DESCRIPTION	ORIGIN (issued by)	APPROVED
REV 001	1/19/22	Document No: 120-011922-001	AP	GM

COMPANY PROPRIETARY INFORMATION

Gilmore Technologies, LLC and/or its affiliates (Gilmore). All rights reserved. Gilmore™, Gilmore & Design (Stallion) are registered trademarks or trademarks of Gilmore. This notice and the information contained herein is not to be, in whole or in part, reproduced or transmitted in any form by any means without the express permission of Gilmore. **DISCLAIMER:** Whilst Gilmore has carefully reviewed the contents of this notice and believes the information to be correct, Gilmore does not assume any liability in connection with any use of or reliance upon this information and gives no representation or warranty, express or implied, in respect of the information or any products described herein. This notice is intended for use by persons having suitable technical expertise and skill, at their own discretion and risk. Gilmore may change the information contained herein at any time without notice.

For more information:

Call (713) 468 8778

Info@gilmore.com

Gilmore
1231 Lumpkin Road
Houston, TX 77043

1-1/2" GEN2 V-Seal Shuttle Valve

Gilmore announces the new 1-1/2" GEN2 V-Seal Shuttle Valve product line for critical offshore and subsea applications. The 1-1/2" GEN2 V-Seal Shuttle Valve has been designed with the same footprint as the legacy Traditional Shuttle Valve for easy drop-in replacement. Gilmore's proprietary dynamic V-Seal technology provides an order of magnitude improvement in valve cycle life.

Features and Benefits:

- Qualification exceeds API 16D requirements
 - Two separate full flow tests at 2500 cycles each
- Proprietary V-Seal and hydraulic damped technology which does not feather or extrude
- Designed and tested to meet 5-year maintenance free service under normal operating conditions
- Improved Valve Materials:
 - 316 SS Body and Flanges
 - Nitronic 60 Shuttle, Sleeve and Cap
 - PEEK Spacer
 - PTFE/Nitrile 90 Duro V-Seal
 - A-286 Cap Screws with T316 Nordlock Washers

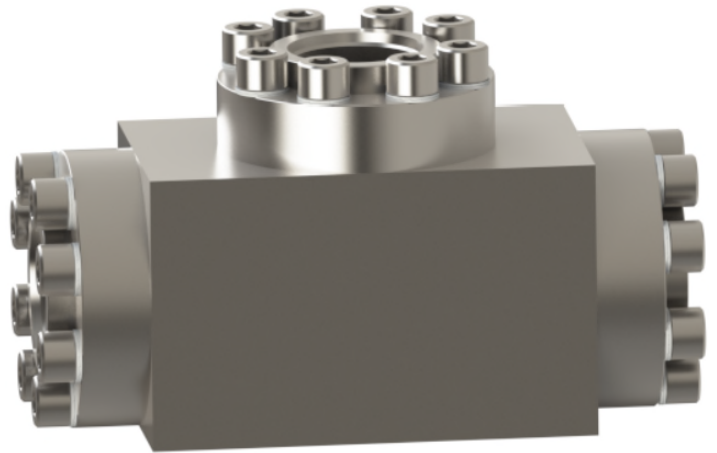

Figure 1. PN 29181: 1-1/2" SAE V-Seal GEN2 Shuttle Valve, 5000 psi, Low interflow

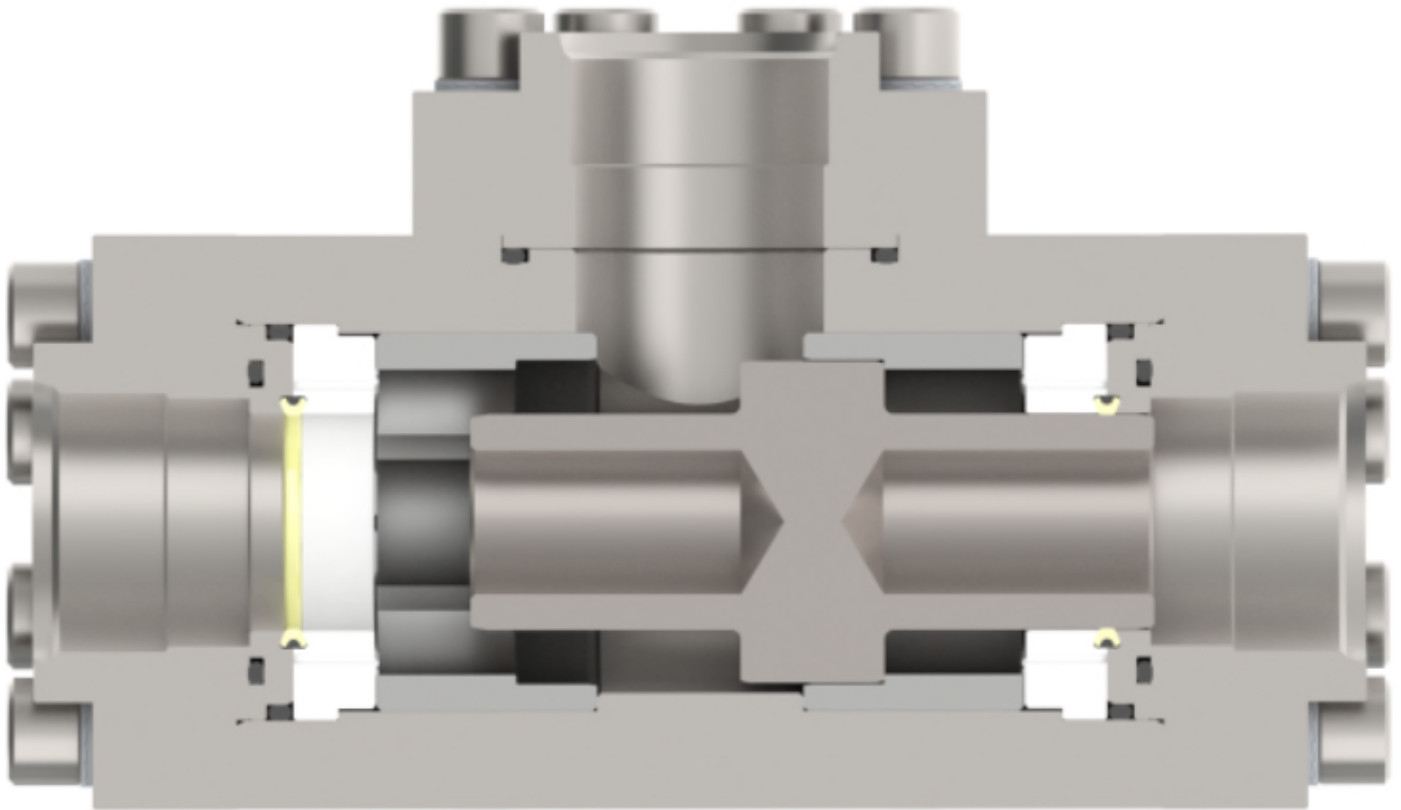

Figure 2. PN 29181: 1-1/2" SAE V-Seal Shuttle Valve, 5000 psi, Low Interflow

1-1/2" GEN2 V-Seal Shuttle Valve

Gilmore has exceeded API 16D requirements by qualifying the new 1-1/2" GEN2 V-Seal Shuttle Valve designs to multiple endurance qualification tests to 2500 cycles, at a starting flow rate of 250 gpm at 5000 psi, with 1% - 4% water glycol test fluid.

The new Gilmore 1-1/2" GEN2 V-Seal Shuttle Valves have an identical footprint to the legacy valves for simple retrofitting.

As a result of the new Gilmore 1-1/2" GEN2 V-Seal Shuttle Valve product line, please note that sales of the legacy 1-1/2" Traditional Shuttle Valve part numbers listed below will be discontinued as of February 1st, 2023. The new Gilmore 1-1/2" GEN2 V-Seal Shuttle Valve is now available as a replacement for the legacy 1-1/2" Traditional Shuttle Valves.

After they are discontinued, Gilmore will continue to support the obsoleted legacy 1-1/2" Traditional Shuttle Valve product line by providing repair kits and seal kits for discontinued 1-1/2" Traditional Shuttle Valves as required for field service. Additionally, Gilmore Aftermarket will continue to support discontinued legacy products with factory failure analysis and repair services as required.

Please note that GEN2 repair kits **are not** interchangeable with legacy repair kits and cannot be used in legacy Traditional Shuttle Valves. Please contact Gilmore Customer Service to assist you with selecting GEN2 replacement valve part numbers.

Table 1. New and Legacy 1-1/2" Shuttle Valve Part Numbers:

Item	Legacy Description	Legacy Valve PN	Legacy Repair Kit PN	New Valve Description	New Valve PN	New Repair Kit PN
1	Valve, 1-1/2", Shuttle, Traditional, 2" Code 62, High Interflow, 5000 psi	28370	28370 RK	Valve, 1-1/2", Shuttle, Gen 2, 2" Code 62, High Interflow, 5000 psi	29180	29180 RK
2	Valve, 1-1/2", Shuttle, Traditional, 1-1/2" SAE, Low Interflow, 5000 psi	25428	25428 RK	Valve, 1-1/2", Shuttle, Gen 2, 1-1/2" SAE, Low Interflow, 5000 psi	29181	29181 RK
3	Valve, 1-1/2", Shuttle, Traditional, 1-1/2" SAE, High Interflow, 5000 psi	25428-1	25428-1 RK	Valve, 1-1/2", Shuttle, Gen 2, 1-1/2" SAE, High Interflow, 5000 psi	29182	29182 RK
4	Valve, 1-1/2", Shuttle, Traditional, 1-1/2" NPT, Low Interflow, 5000 psi	25414	25414 RK	Valve, 1-1/2", Shuttle, Gen 2, 1-1/2" NPT, Low Interflow, 5000 psi	29183	29183 RK
5	Valve, 1-1/2", Shuttle, Traditional, 1-1/2" NPT, High Interflow, 5000 psi	25430	25430 RK	Valve, 1-1/2", Shuttle, Gen 2, 1-1/2" NPT, High Interflow, 5000 psi	29184	29184 RK
6	Valve, 1-1/2", Shuttle, Traditional, 1-1/2" Code 62, Low Interflow, 5000 psi	27405	27405 RK	Valve, 1-1/2", Shuttle, Traditional, 1-1/2" Code 62, Low Interflow, 5000 psi	29191	29191 RK
7	Valve, 1-1/2", Shuttle, Traditional, 2" Code 62, Low Interflow, 5000 psi	28189	28189 RK	Valve, 1-1/2", Shuttle, Gen 2, 2" Code 62, Low Interflow, 5000 psi	29190	29190 RK

Please contact Gilmore Customer Service to request drawings and quotations for these new GEN2 shuttle valves at Info@gilmore.com.