

1/2" Quick Dump Valve Product Line

REV	DATE	DESCRIPTION	ORIGIN (issued by)	APPROVED
Rev 002	02-03-2017	Document No: 115-020317-002	AP	SS
Rev 001	02-03-2017	Document No: 115-020317-001	AP	SS

COMPANY PROPRIETARY INFORMATION

Gilmore Technologies, LLC and/or its affiliates (Gilmore). All rights reserved. Gilmore™, Gilmore & Design (Stallion) are registered trademarks or trademarks of Gilmore. This notice and the information contained herein is not to be, in whole or in part, reproduced or transmitted in any form by any means without the express permission of Gilmore. **DISCLAIMER:** Whilst Gilmore has carefully reviewed the contents of this notice and believes the information to be correct, Gilmore does not assume any liability in connection with any use of or reliance upon this information and gives no representation or warranty, express or implied, in respect of the information or any products described herein. This notice is intended for use by persons having suitable technical expertise and skill, at their own discretion and risk. Gilmore may change the information contained herein at any time without notice.

For more information:

Call (713) 468 8778

Info@gilmore.com

Gilmore
1231 Lumpkin Road
Houston, TX 77043

1/2" Quick Dump Valve Product Line

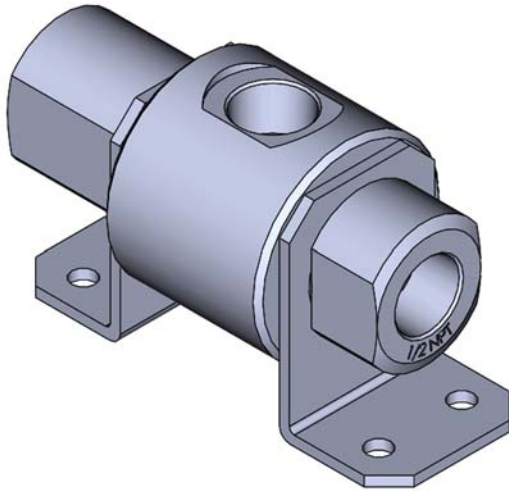

New Gilmore 1/2" Quick Dump Valve Product Line

Gilmore's 1/2" Quick Dump Valves are used to enable quick dumping of a cylinder, pilot or circuit function volume (e.g. subsea riser connector). The 1/2" Quick Dump Valve vent port will bypass a restrictive upstream control system vent circuit.

Features and Benefits:

- Nitronic 60 Spool with self-centering metal seat geometry
- Nitronic 60 Poppet
- Nitronic 60 Seat with O-Ring seal

The new Gilmore 1/2" Quick Dump Valve product line offers the following enhancements over the legacy product line:

- Field repairable
- Elimination of the need to coin each valve
- Meets the latest Proserv Gilmore material specifications
- Fits the same footprint as the legacy Gilmore 1/2" Quick Dump Valve

Figure 1. PN 29010: 1/2" NPT Quick Dump Valve

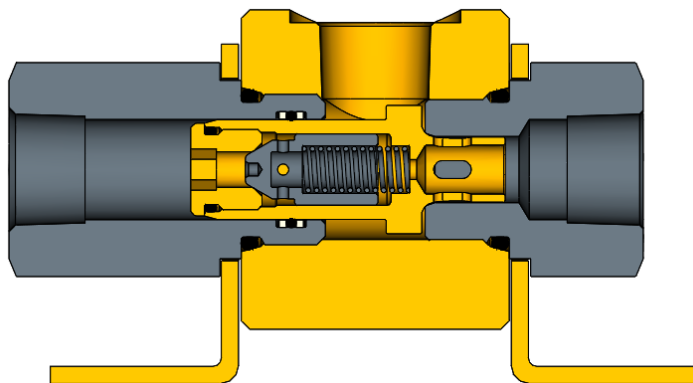

Gilmore has exceeded API 16D requirements by qualifying two each of the new 1/2" Quick Dump Valve design to 2500 cycles.



The improved 1/2" Quick Dump Valve and its applicable repair kits and seal kits are available for sale immediately by utilizing the applicable part number from Table 1 below and by contacting your Gilmore Customer Service Representative.

Gilmore will continue selling the legacy 1/2" Quick Dump Valve part numbers listed in Table 1 below until February 3, 2018, at which time the legacy valves will be discontinued, no longer available for sale.

Gilmore will continue to support discontinued legacy 1/2" Quick Dump Valves as follows:

- Gilmore will continue providing repair kits and seal kits in support of discontinued 1/2" Quick Dump Valves for a minimum of 3 years from the date of legacy valve obsolescence.
- Gilmore Aftermarket will continue to support discontinued legacy products with factory failure analysis and repair services for a minimum of 3 years from the date of legacy valve obsolescence.

Table 1. New and Legacy 1/2" Quick Dump Valve Part Numbers:

Item	Legacy Description	Legacy Valve PN	Legacy Repair Kit PN	New Valve Description	New Valve PN	New Repair Kit PN
1	Valve, Quick Dump, 1/2 NPT	27627	27627 RK	Valve, Quick Dump, 1/2 NPT, Seat O-Ring	29010	29010 RK
2	Valve, Quick Dump, 1/2 SAE	28291	28291 RK	Valve, Quick Dump, 1/2 SAE, Seat O-Ring	29011	29011 RK