

1/2" GEN2 SPM Cartridge & Valve Product Line

REV	DATE	DESCRIPTION	ORIGIN (issued by)	APPROVED
001	01-24-2020	Document No: 105-012420-001	AP	BR

COMPANY PROPRIETARY INFORMATION

Gilmore Technologies, LLC and/or its affiliates (Gilmore). All rights reserved. Gilmore™, Gilmore & Design (Stallion) are registered trademarks or trademarks of Gilmore. This notice and the information contained herein is not to be, in whole or in part, reproduced or transmitted in any form by any means without the express permission of Gilmore. **DISCLAIMER:** Whilst Gilmore has carefully reviewed the contents of this notice and believes the information to be correct, Gilmore does not assume any liability in connection with any use of or reliance upon this information and gives no representation or warranty, express or implied, in respect of the information or any products described herein. This notice is intended for use by persons having suitable technical expertise and skill, at their own discretion and risk. Gilmore may change the information contained herein at any time without notice.

For more information:

Call (713) 468 8778
info@gilmore.com

Gilmore
 1231 Lumpkin Road
 Houston, TX 77043

1/2" GEN2 SPM Cartridge & Valve Product Line



Gilmore announces the new 1/2 inch GEN 2 SPM product line for critical offshore and subsea applications. The 1/2 inch GEN 2 SPM has been redesigned with significant improvements, within the same cavity and footprint as the legacy SPM, allowing direct replacement in existing Gilmore SPM manifolds. Gilmore's proprietary cartridge technology provides an order of magnitude improvement in SPM cycle life.

Features and Benefits:

- Qualification exceeds API 16D requirements –
 - Two separate full flow tests at 2500 cycles each
- Proprietary bi-directional cartridge performs in both Normally Closed or Normally Open applications
- Reduces interflow
- Improved valve materials:
 - 316 SS Body and Spring
 - Nitronic 50 Piston Rod
 - Nitronic 60 Seal Sleeve and Cage
 - Aluminium Bronze Bushing
 - Shouldered and Torqued Nylon Lock Nut
 - Dynamic T-Seals
 - HNBR Soft Seals with PEEK Double Back-up Rings
 - Delrin 511P Top and Bottom Seals
- Wide array of options available for body and port style, and customized manifold assemblies
- Patent Pending

Figure 1. PN 29078: ½ inch GEN 2 SPM Valve, N.C., ½ inch NPT, 5000 psi Supply, 5000 psi Pilot

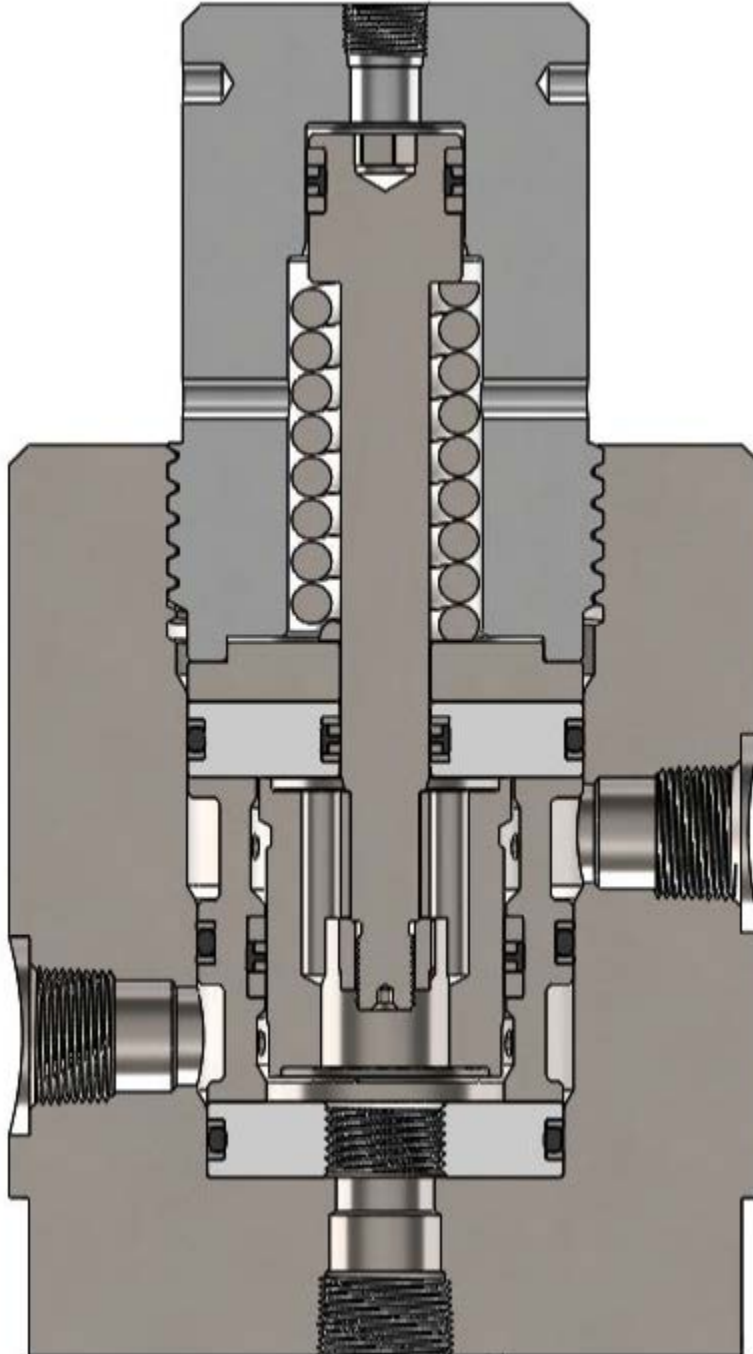

Gilmore has met or exceeded API 16D requirements by qualifying the new ½ inch GEN 2 SPM designs to multiple endurance qualification tests to 2500 cycles at 5000 psi and 75gpm with 1% - 4% water glycol test fluid.



The new ½ inch GEN 2 SPM Cartridge and Valve have the identical cavity and valve footprint dimensions as the legacy SPM, allowing drop-in replacement.

As a result of the new Gilmore ½ inch GEN 2 SPM product line, please note that sales of the legacy ½ inch SPM Cartridge and Valve part numbers listed below will be discontinued as of January 24, 2021. The new Gilmore ½ inch GEN 2 SPM Cartridge and Valves are now available as a replacement for the legacy ½ inch SPM Cartridge and Valves.

After new valve sales are discontinued, Gilmore will continue to support the legacy ½ inch SPM product line:

- Gilmore will continue providing repair kits and seal kits in support of discontinued legacy ½ inch SPM Cartridge and Valves for a minimum of three years. The legacy ½ inch SPM Cartridge and Valves listed below can be repaired in the field.
- Gilmore Aftermarket will continue to support discontinued legacy products with factory failure analysis and repair services for a minimum of three years.

Please note that GEN 2 repair kits are not interchangeable with legacy repair kits and cannot be used in legacy SPMs. Please contact Gilmore Customer Service to assist you with selecting the GEN 2 replacement valve part numbers.

Table 1. New and Legacy ½ inch SPM Part Number Cross References:

Item	Legacy Description	Legacy Valve PN	Legacy Repair Kit PN	GEN 2 Cartridge or Valve Description	GEN 2 Valve PN	GEN 2 Repair Kit PN
1.1	Valve, ½ inch SPM, N.O., 1/2 NPT Block Ports, 1/4 NPT Pilot Port	27610-1	27165-2 RK	Valve, ½ inch GEN 2 SPM, N.O., 1/2 NPT Block Ports, 1/4 NPT Pilot Port	29078	29078 RK
1.2	Valve, ½ inch SPM, N.C., 1/2 NPT Block Ports, 1/4 NPT Pilot Port	27611-1	27166-2 RK	Valve, ½ inch GEN 2 SPM, N.C., 1/2 NPT Block Ports, 1/4 NPT Pilot Port	29079	29079 RK
1.3	Valve, ½ inch SPM, N.O., 1/2 NPT Block Ports, 1/4 NPT Pilot Port, 1/4 NPT Flushing Port	173847	174413	Valve, ½ inch GEN 2 SPM, N.O., 1/2 NPT Block Ports, 1/4 NPT Pilot Port, 1/4 NPT Flushing Port	29085	29085 RK
1.4	Valve, ½ inch SPM, N.C., 1/2 NPT Block Ports, 1/4 NPT Pilot Port, 1/4 NPT Flushing Port	173848	174415	Valve, ½ inch GEN 2 SPM, N.C., 1/2 NPT Block Ports, 1/4 NPT Pilot Port, 1/4 NPT Flushing Port	29086	29086 RK
1.5	Cartridge, ½ inch SPM, N.O., 1/4 NPT Pilot Port	27165-2	27165-2 RK	Cartridge, ½ inch GEN 2 SPM, N.O. and N.C., 1/4 NPT Pilot Port	29076	29076 RK
1.6	Cartridge, ½ inch SPM, N.C., 1/4 NPT Pilot Port	27166-2	27166-2 RK	Cartridge, ½ inch GEN 2 SPM, N.O. and N.C., 1/4 NPT Pilot Port	29076	29076 RK
1.7	Cartridge, ½ inch SPM, Low Interflow, N.C., 1/4 NPT Pilot Port	27166-3	27166-3 RK	Cartridge, ½ inch GEN 2 SPM, N.O. and N.C., 1/4 NPT Pilot Port	29076	29076 RK

Item	Legacy Description	Legacy Valve PN	Legacy Repair Kit PN	GEN 2 Cartridge or Valve Description	GEN 2 Valve PN	GEN 2 Repair Kit PN
1.8	Cartridge, ½ inch SPM, N.O., 1/4 NPT Pilot Port, Delrin Seats	27165-5	27165-5 RK	Cartridge, ½ inch GEN 2 SPM, N.O. and N.C., ¼ NPT Pilot Port	29076	29076 RK
1.9	Cartridge, ½ inch SPM, N.C., 1/4 NPT Pilot Port, Delrin Seats	27166-5	27166-5 RK	Cartridge, ½ inch GEN 2 SPM, N.O. and N.C., 1/4 NPT Pilot Port	29076	29076 RK
1.10	Cartridge, ½ inch SPM, N.O., 1/4 NPT Pilot Port, Delrin Seats	28480	28480 RK	Cartridge, ½ inch GEN 2 SPM, N.O. and N.C., 1/4 NPT Pilot Port	29076	29076 RK
1.11	Cartridge, ½ inch SPM, N.C., 1/4 NPT Pilot Port, Delrin Seats	28479	28479 RK	Cartridge, ½ inch GEN 2 SPM, N.O. and N.C., 1/4 NPT Pilot Port	29076	29076 RK
1.12	Cartridge, ½ inch SPM, N.O., 1/4 NPT Pilot Port, 1/4 NPT Flushing Port	173849	174413	Cartridge, ½ inch GEN 2 SPM, N.O. and N.C., 1/4 NPT Pilot Port, 1/4 NPT Flushing Port	29077	29077 RK
1.13	Cartridge, ½ inch SPM, N.C., 1/4 NPT Pilot Port, 1/4 NPT Flushing Port	173850	174415	Cartridge, ½ inch GEN 2 SPM, N.O. and N.C., 1/4 NPT Pilot Port, 1/4 NPT Flushing Port	29077	29077 RK



Table 2. Uncommon Legacy 1/2 inch SPM Valve Part Numbers

Item	Legacy Description	Legacy Valve PN	Legacy Repair Kit PN	GEN 2 Valve Description	GEN 2 Valve PN	GEN 2 Repair Kit PN
2.1	Valve, Dual, 1/2 inch SPM, Low Interflow, N.C., 1/2 NPT Block Ports, 1/4 NPT Pilot Port	156593	156691	Valve, Dual, 1/2 inch GEN 2 SPM, N.C., 1/2 NPT Block Ports, 1/4 NPT Pilot Port	29083	29083 RK
2.2	Valve, Dual, 1/2 inch SPM, N.C., 1/2 NPT Block Ports, 1/4 NPT Pilot Port	90605	90605 RK	Valve, Dual, 1/2 inch GEN 2 SPM, N.C., 1/2 NPT Block Ports, 1/4 NPT Pilot Port	29083	29083 RK
2.3	Valve, 1/2 inch SPM, 2-Way, N.C., 1/2 NPT Block Ports, 1/4 NPT Pilot Port	178248	178942	Valve, 1/2 inch GEN 2 SPM, 2-Way, N.C., 1/2 NPT Block Ports, 1/4 NPT Pilot Port	29087	29087 RK
2.4	Cartridge, 1/2 inch SPM, N.O., 1/4 BSPP Pilot Port	28394	28394 RK	Cartridge, 1/2 inch GEN 2 SPM, N.C. and N.O., 1/4 BSPP Pilot Port	29076-1	29076-1 RK
2.5	Cartridge, 1/2 inch SPM, N.C., 1/4 BSPP Pilot Port	28396	28396 RK	Cartridge, 1/2 inch GEN 2 SPM, N.C. and N.O., 1/4 BSPP Pilot Port	29076-1	29076-1 RK
2.6	Cartridge, 1/2 inch SPM, N.C., 1/4 SAE Pilot Port	179213	179214	Cartridge, 1/2 inch GEN 2 SPM, N.C. and N.O., 1/4 SAE Pilot Port	29076-2	29076-2 RK
2.7	Cartridge, 1/2 inch SPM, N.O., Pneumatic Pilot, 3/4 NPT Pilot Port	27501-2	27501-2 RK	Cartridge, 1/2 inch GEN 2 SPM, N.C. and N.O., Pneumatic Pilot, 3/4 NPT Pilot Port	29080	29080 RK
2.8	Cartridge, 1/2 inch SPM, 2-Way, N.C., 1/4 NPT Pilot Port	179029	179122	Cartridge, 1/2 inch GEN 2 SPM, 2-Way, N.C., 1/4 NPT Pilot Port	29081	29081 RK
2.9	Cartridge, 1/2 inch SPM, 2-Way, N.C., 1/4 BSPP Pilot Port	28508	28508 RK	Cartridge, 1/2 inch GEN 2 SPM, 2-Way, N.C., 1/4 BSPP Pilot Port	29081-1	29081-1 RK
2.10	Cartridge, 1/2 inch SPM, 2-Way, N.O., 1/4 BSPP Pilot Port	28509	28509 RK	Cartridge, 1/2 inch GEN 2 SPM, 2-Way, N.O., 1/4 BSPP Pilot Port	29081-2	29081-2 RK
2.11	Cartridge, 1/2 inch SPM, Low Interflow, N.O., 1/2 NPT Block Ports, 3/8 MP Pilot Port	27165-4	27165-4 RK	Cartridge, 1/2 inch GEN 2 SPM, N.C. and N.O., 3/8 MP Pilot Port	29082	29082 RK
2.12	Cartridge, 1/2 inch SPM, Low Interflow, N.C., 1/2 NPT Block Ports, 3/8 MP Pilot Port	27166-4	27166-4 RK	Cartridge, 1/2 inch GEN 2 SPM, N.C. and N.O., 3/8 MP Pilot Port	29076-3	29076-3 RK



Gilmore will continue supporting all listed legacy valves through repair kits, seal kits and aftermarket support for a minimum of 3 years.

Please contact Gilmore Customer Service to request drawings and quotations for these SPMs at info@gilmore.com.