

1" GEN2 Quarter Turn Rotary Selector Valve

REV	DATE	DESCRIPTION	ORIGIN (issued by)	APPROVED
REV 001	12/20/23	Document No: 130-122023-001	AJP	BR

COMPANY PROPRIETARY INFORMATION

© Proserv Gilmore Valve, LLC and/or its affiliates (Gilmore). All rights reserved. Proserv®, Gilmore™, Gilmore & Design (Stallion) are registered trademarks or trademarks of Gilmore. This notice and the information contained herein is not to be, in whole or in part, reproduced or transmitted in any form by any means without the express permission of Gilmore. **DISCLAIMER:** Whilst Gilmore has carefully reviewed the contents of this notice and believes the information to be correct, Gilmore does not assume any liability in connection with any use of or reliance upon this information and gives no representation or warranty, express or implied, in respect of the information or any products described herein. This notice is intended for use by persons having suitable technical expertise and skill, at their own discretion and risk. Gilmore may change the information contained herein at any time without notice.

For more information:

INFO@Gilmore.com

Gilmore
1231 Lumpkin Road
Houston, TX 77043

1" GEN2 Quarter Turn Rotary Selector Valve

Gilmore announces the new 1" GEN2 Quarter Turn Rotary Selector Valve product line for critical onshore and topside applications. Gilmore's proprietary Tungsten Carbide seal trim combined with the stabilized rotor design provides an order of magnitude improvement in valve cycle life over typical rotary selector valves.

Features and Benefits:

- Qualification exceeds API 16D requirements
 - Two separate full flow tests at 2500 cycles each
- Proprietary Tungsten Carbide Seal Trim technology for increased cycle life
- Stabilized Rotor design enables high flow rate and vent pressure
- Valve Materials:
 - 4130 Housing and Cover
 - Aluminum Bronze Rotor
 - HNBR Elastomers
 - Nitronic 60 Stem

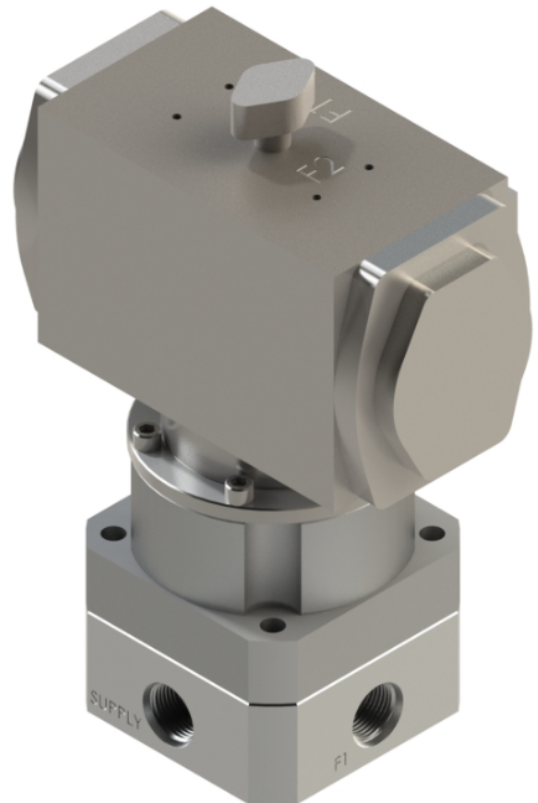
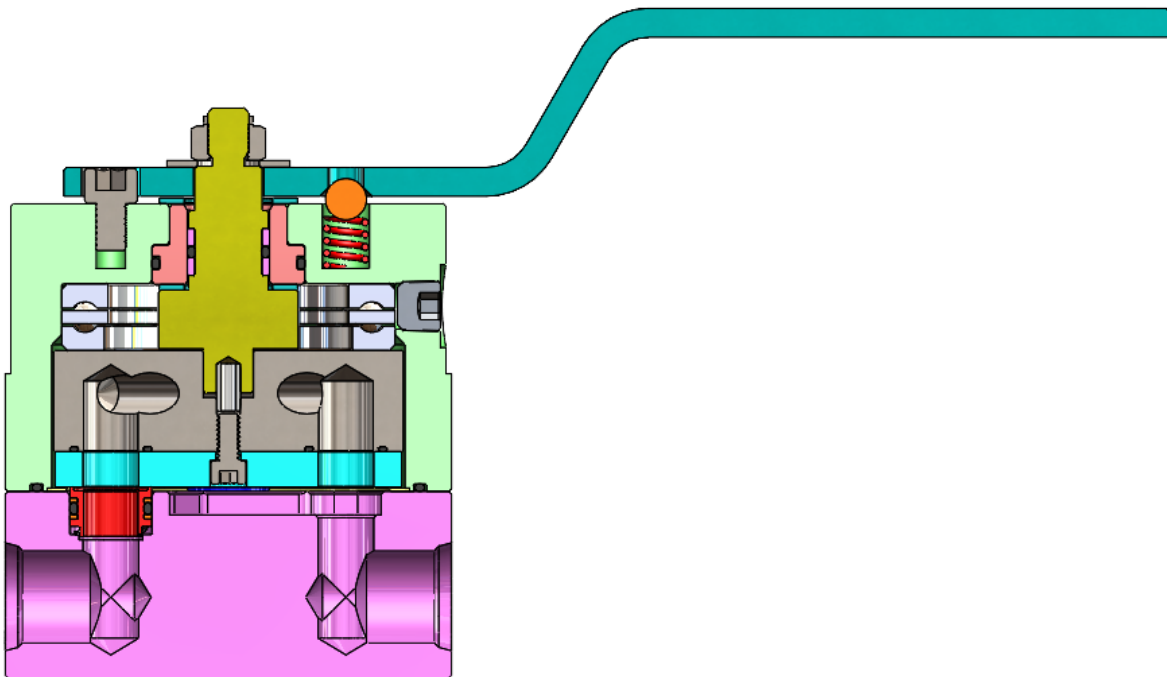

Figure 1. PN 29204: 3/4" SAE, Pneumatically Actuated, 2-Position, 4-Way, GEN2 Quarter Turn Rotary Selector Valve, 5000 psi



Figures 2 & 3. PN 29205: 3/4" SAE, Wrench Operated, 3-Position, 4-Way, GEN2 Quarter Turn Rotary Selector Valve, 5000 psi

1" GEN2 Quarter Turn Rotary Selector Valve

Gilmore has exceeded API 16D requirements by qualifying the new 1" GEN2 Quarter Turn Rotary Selector Valve designs to two separate endurance qualification tests to 2500 cycles, at a flow rate of 115 gpm at 5000 psi, with 1% - 4% water-glycol hydraulic control test fluid.

Table 1. New 1" GEN2 Quarter Turn Rotary Selector Valve Part Numbers:

Item	New Valve Description	New Valve PN	New Repair Kit PN
1	Valve, GEN2, 1 inch, Rotary Selector, 4-Way, Closed Center, Pneumatic QT Actuator, Topside, ¾ inch SAE Ports	29204	29204 RK
2	Valve, GEN2, 1 inch, Rotary Selector, 4-Way, Closed Center, Manual Wrench, Topside, ¾ inch SAE Ports	29205	29205 RK
3	Valve, GEN2, 1 inch, Rotary Selector, 4-Way, Closed Center, Manual Wrench, Topside, Manifold Mount	29207	29207 RK

The new product family of 1" Quarter Turn Rotary Selector Valves designs are now available. Specific customer requirements for actuators and accessories will be accommodated by request.

Please contact Gilmore Customer Service to request drawings and quotations for these new GEN2 Quarter Turn Rotary Selector valves at Sales@gilmore.com.