



1" & 1-1/2" GEN2 Check Valve Product Line

REV	DATE	DESCRIPTION	ORIGIN (issued by)	APPROVED
REV 002	9/06/22	Document No: 100-063021-002	AP	BR
REV 001	6/30/21	Document No: 100-063021-001	AP	GM

COMPANY PROPRIETARY INFORMATION

© 2014 - 2022 Proserv Gilmore Valve, LLC and/or its affiliates (Gilmore). All rights reserved. Proserv®, Gilmore™, Gilmore & Design (Stallion) and Gilmore, a Proserv Company™ are registered trademarks or trademarks of Gilmore. This Bulletin and the information contained herein is not to be, in whole or in part, reproduced or transmitted in any form by any means without the express permission of Gilmore. DISCLAIMER: Whilst Gilmore has carefully reviewed the contents of this Bulletin and believes the information to be correct, Gilmore does not assume any liability in connection with any use of or reliance upon this information and gives no representation or warranty, express or implied, in respect of the information or any products described herein. This Bulletin is intended for use by persons having suitable technical expertise and skill, at their own discretion and risk. Gilmore may change the information contained herein at any time without notice.

For more information:
info@gilmore.com

Gilmore
1231 Lumpkin Road
Houston, TX 77043

1" & 1-1/2" GEN2 Check Valve Product Line

Gilmore announces the new GEN2 Check Valve product line for critical offshore and subsea applications. The 1" & 1-1/2" GEN2 Check Valves have been redesigned with significant improvements, within the same cavity & footprint as the legacy Check Valve, allowing direct replacement inline or within existing Gilmore Check Valve Cartridge manifolds. Gilmore's proprietary valve technology provides an order of magnitude improvement in cycle life.

Features and Benefits:

- Qualification exceeds API 16D requirements
 - Two valves, 2500 cycles each
- Multiple cracking pressure options
- Improved Seat design
- Bolted Cover design
- Damped SealSleeve
- Improved valve materials:
 - A286 Gr 660 SHCS
 - 17-4 (H1150D) Body
 - Inconel X-750 Spring
 - Nitronic 60 Seal Sleeve and Cage
 - Nitronic 60 Piston Rod
 - PEEK Back Up rings
 - HNBR Soft Seals
 - Delrin 511P Seats

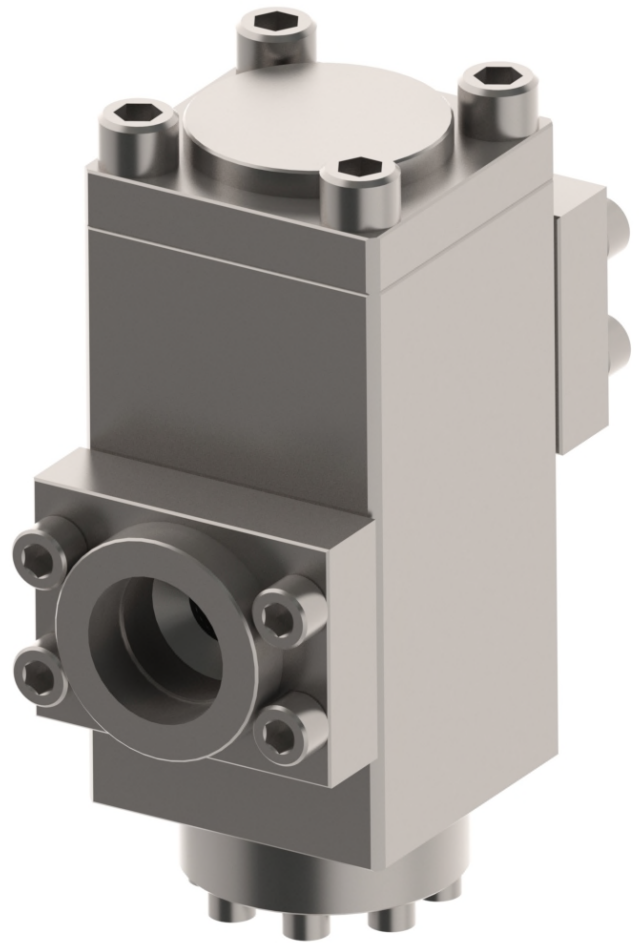
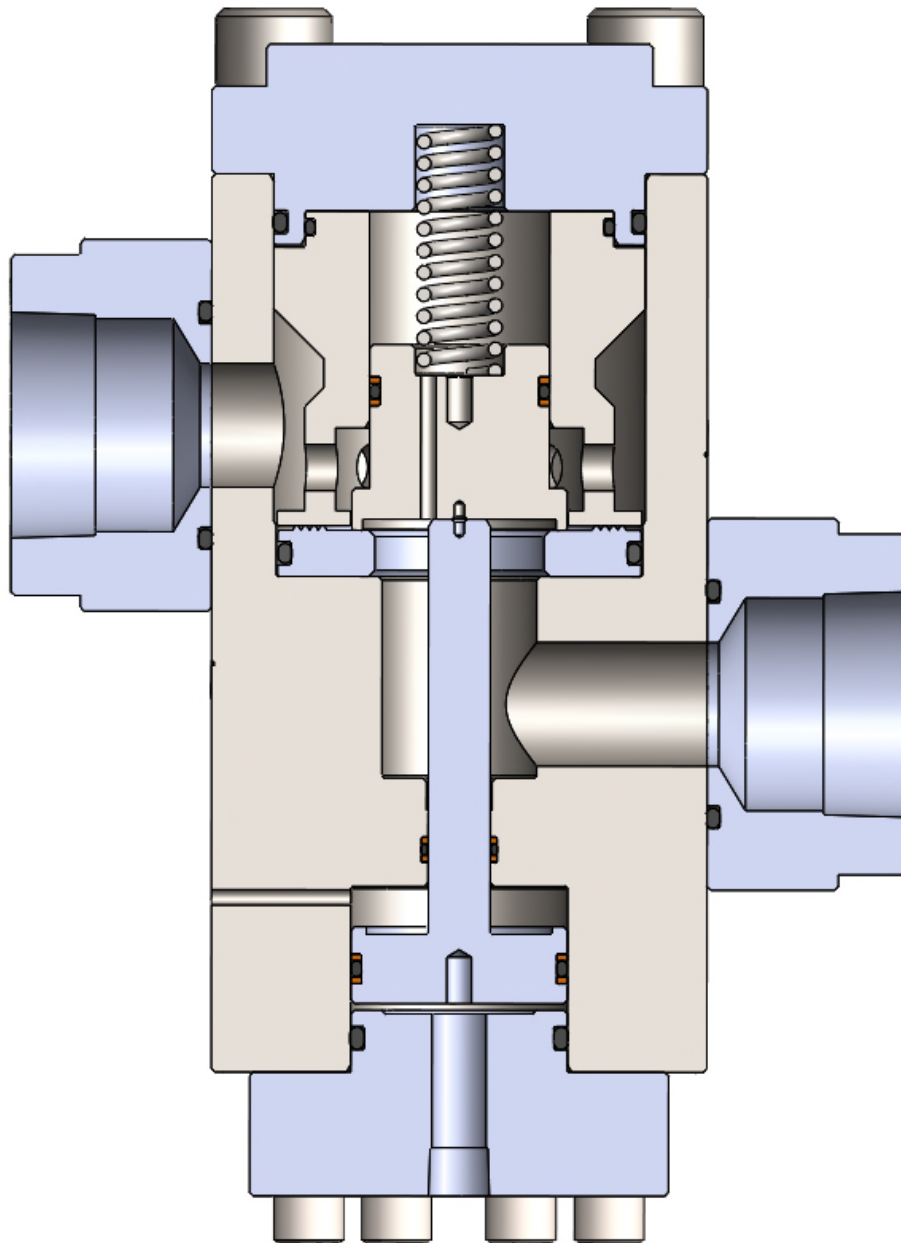

Figure 1. PN 29153: GEN2 Check valve, Pilot Operated,
Externally Vented Piston, 1-1/2 NPT, 5 ksi MAWP

1" & 1-1/2" GEN2 Check Valve Product Line

Figure 2.

PN 29153: GEN2 Check Valve, Pilot Operated, Externally Vented Piston, 1-1/2 NPT, 5 ksi MAWP



1" & 1-1/2" GEN2 Check Valve Product Line

Gilmore has exceeded API 16D requirements by qualifying the new Gilmore 1" and 1-1/2" GEN2 Check Valves to 2,500 cycles, with a 1" flow rate of 200 gpm and 1-1/2" flow rate of 300 gpm, at 5000 psi inlet with 1% - 4% water glycol test fluid.

The new 1" & 1-1/2" GEN2 Check Cartridge and Valve have the identical cavity and valve footprint dimensions as the legacy Check Valves, allowing drop-in replacement.

Gilmore will continue to sell and support the legacy 1" and 1-1/2" Check Valves with new valve sales, repair kits, seal kits and Aftermarket support.

The new 1" & 1-1/2" GEN2 Check Cartridge and Valve listed below are now available as drop-in replacements for the legacy 1" & 1-1/2" Check Cartridge and Valve:

Table 1. New and Legacy 1" Check Valve and Cartridge Part Number Cross Reference:

Item	Legacy Description	Legacy Valve PN	Legacy Repair Kit PN	GEN2 Description	New Valve PN	New Repair Kit PN
1	Valve, 1" Check, Piloted, Internal Vent, Standard Cracking, 5 ksi Inlet, 1" NPT Ports, 1/4" NPT Pilot	25100	25100 RK	Valve, 1" Check, GEN2, Piloted, Internal Vent, Standard Cracking, 5 ksi Inlet, 1" NPT Ports, 1/4" NPT Pilot	29142	29142 RK
2	Valve, 1" Check, Piloted, Internal Vent, Standard Cracking, 5 ksi Inlet, 1" SAE Ports, 3/8" SAE Pilot	25145 28493	25145 RK 28493 RK	Valve, 1" Check, GEN2, Piloted, Internal Vent, Standard Cracking, 5 ksi Inlet, 1" SAE, 3/8" SAE Pilot	29146	29146 RK
3	Valve, 1" Check, Non-Piloted, Low Cracking, 5 ksi Inlet, 1" NPT Ports	27232-4	27232-4 RK	Valve, 1" Check, GEN2, Non-Piloted, Low Cracking, 5 ksi Inlet, 1" NPT Ports (Legacy Body Dimensions)	29173	29173 RK
4	Valve, 1" Check, Non-Piloted, Low Cracking, 5 ksi Inlet, 1" SAE Ports	27232-3	27232-3 RK	Valve, 1" Check, GEN2, Non-Piloted, Low Cracking, 5 ksi Inlet, 1" SAE Ports (Legacy Body Dimensions)	29185	29185 RK
5	Valve, 1" Check, Non-Piloted, Standard Cracking, 5 ksi Inlet, 1" SAE Ports	27232-2	27232-2 RK	Valve, 1" Check, GEN2, Non-Piloted, Standard Cracking, 5 ksi Inlet, 1" SAE (Legacy Body Dimensions)	29174	29174 RK
6	Cartridge, 1" Check, Standard Cracking, 5 ksi Inlet	27162	27162 RK	Cartridge, 1" Check, GEN2 Standard Cracking, 5 ksi Inlet (Legacy Bolting Pattern)	29179	29179 RK



1" & 1-1/2" GEN2 Check Valve Product Line

Table 2. New and Legacy 1-1/2" Check Valve and Cartridge Part Number Cross Reference:

Item	Legacy Description	Legacy Valve PN	Legacy Repair Kit PN	GEN2 Description	New Valve PN	New Repair Kit PN
7	Double Valve, 1-1/2" Check, Piloted, Standard Cracking, 5 ksi Inlet, 1-1/2" SW ports, 1/4" NPT Pilot	25155-0.2	25155-0.2 RK	Double Valve, 1-1/2" Check, GEN2, Piloted, Standard Cracking, 5 ksi Inlet, 1-1/2" SW Ports, 1/4" NPT Pilot	29158	29158 RK
8	Double Valve, 1-1/2" Check, Non-Piloted, Standard Cracking, 5 ksi Inlet, 1-1/2" Code 62 Ports	28608	28608 RK	Double Valve, 1-1/2" Check, GEN2, Non-Piloted, Standard Cracking, 5 ksi Inlet, 1-1/2" Code 62 Ports	29157	29157 RK
9	Valve, 1-1/2" Check, Piloted, Low Cracking, 5 ksi Inlet, 1-1/2" NPT Ports, 1/4" NPT Pilot	28485	28485 RK	Valve, 1-1/2" Check, GEN2, Piloted, Externally Vented, Low Cracking, 5ksi Inlet, 1-1/2" NPT Ports, 1/4" NPT Pilot	29153	29153 RK
10	Valve, 1-1/2" Check, Non-Piloted, 5 ksi Inlet, 2" Code 62 Ports	28260	28260 RK	Valve, 1-1/2" Check, GEN2, Non-Piloted, Standard Cracking, 5 ksi Inlet, 2" Code 62 Ports	29147	29147 RK
11	Valve, 1-1/2" Check, Non-Piloted, Standard Cracking, 5 ksi Inlet, 1-1/2" NPT Ports	27235-1	27235-1 RK	Valve, 1-1/2" Check, GEN2, Non-Piloted, Standard Cracking, 5 ksi Inlet, 1-1/2" NPT Ports (Legacy Body Dimensions)	29170	29170 RK
12	Valve, 1-1/2" Check, Non-Piloted, Low Cracking, 5 ksi Inlet, 1-1/2" Code 62 Ports	27235-3	27235-3 RK	Valve, 1-1/2" Check, GEN2, Non-Piloted, Low Cracking Pressure, 5 ksi Inlet, 1-1/2" Code 62 Ports (Legacy Body Dimensions)	29171	29171 RK
13	Valve, 1-1/2" Check, Non-Piloted, Standard Cracking, 5 ksi Inlet, 2" Code 62 Ports, Offset Spool	28521	28526 RK	Valve, 1-1/2" Check, GEN2, Non-Piloted, Standard Cracking, 5 ksi Inlet, 2" Code 62 Ports, Offset Spool	29154	29154 RK
14	Cartridge, 1-1/2" Check, Low Cracking, 5 ksi Inlet	25120-0.2 209012	25120-0.2 RK 209012 RK	Cartridge, 1-1/2" Check, GEN2, Low Cracking, 5 ksi Inlet (Legacy Bolt Pattern)	29172	29172 RK



Product Information Bulletin

1" & 1-1/2" GEN2 Check Valve Product Line

Please note that GEN2 Check valve and GEN2 Pilot Operated Check Valve kits **are not** interchangeable with legacy repair kits and seal kits and cannot be used in legacy check valves. Please contact Gilmore Customer Service to assist you with drawings and quotations when selecting a GEN2 check valve replacement part number, Sales@gilmore.com.

Table 3. Further GEN2 Part Numbers with additional standardization and features:

Item	Additional GEN2 Description	Additional GEN2 Valve PN	Additional GEN2 Repair Kit PN	Comment
15	Valve, 1" Check, GEN2, Piloted, External Vent, Standard Cracking, 5 ksi Inlet, 1" SAE Ports, 3/8" SAE Pilot	29175	29175 RK	Same as GEN2 PN 29142 except externally vented
16	Valve, 1" Check, GEN2, Non-Piloted, Low Cracking, 5 ksi Inlet, 1" NPT Ports	29140	29140 RK	Same as GEN2 PN 29173 except weight reduced
17	Valve, 1" Check, GEN2, Non-Piloted, Low Cracking, 5 ksi Inlet, 1" SAE Ports	29186	29186 RK	Same as GEN2 PN 29185 except weight reduced
18	Valve, 1" Check, GEN2, Non-Piloted, Standard Cracking, 5 ksi Inlet, 1" SAE Ports	29145	29145 RK	Same as GEN2 PN 29174 except weight reduced
19	Valve, 1-1/2" Check, GEN2, Non-Piloted, Low Cracking, 5 ksi Inlet, 1-1/2" Code 62 Ports	29152	29152 RK	Same as GEN2 PN 29171 except weight reduced
20	Valve, 1-1/2" Check, GEN2, Non-Piloted, Standard Cracking, 5 ksi Inlet, 1-1/2" NPT Ports	29151	29151RK	Same as GEN2 PN 29170 except weight reduced