

## Proserv Subsea Open Communication Hub (OCH)

Retrofitting new instrumentation or extending field of an existing installation has always been a challenging process until now. The Open Communication Hub (OCH) does something not normally done in subsea operation. It simplifies. The OCH is part of an entire system that reduces the complexity of connecting seemingly disparate systems and provides an interface for up to six instruments using only one pair of umbilical power cables for data transmission.

The OCH works with all major trees and control systems to create a transparent communication system.

### Features & Benefits

- Allows fully transparent communications to subsea
- Multiple subsea interfaces - Ethernet, Serial, IWIS, SIIIS
- Fully redundant with dual canisters
- Can be daisy-chained to another OCH HUB
- Integrated web server which allows full configuration and diagnostics of the communications using any standard browser
- Provision to connect up to 6 different devices with different protocols
- Expands existing subsea network beyond current limitations
- Can be retro-fitted in to an existing production system or new developments

### Applications

- Multi-phase flow metering
- Water cut meter
- Environmental monitoring
- Leakage detection
- Subsea video monitoring
- Condition/vibration monitoring
- Riser/spool monitoring (inc. data logger)
- Corrosion monitoring
- Sand monitoring
- Combinations

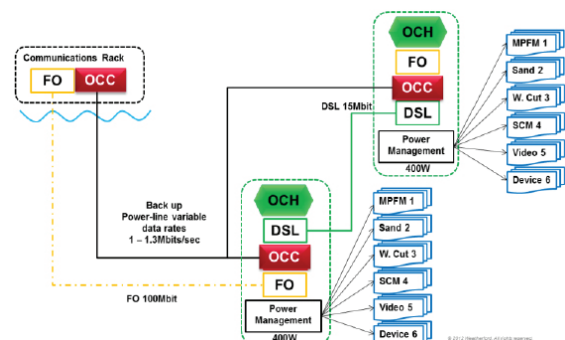
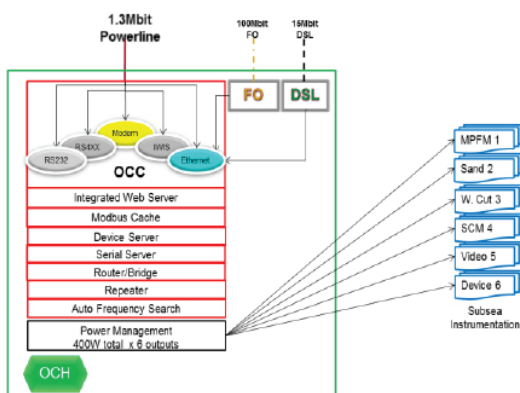

ingenious simplicity

info@proserv.com

www.proserv.com

Technical Specification	
Typical configuration (can be configured to project specification)	
Footprint (L x W x H)	1200 x 1000 x 1359.4 mm - customisable
Weight	Dry: 1050 kg, Submerged: 850 kg
Power consumption	OCH module, 50 Watt. Total load: 400 Watt x 2
Design standard	ISO 13628-6
Design Depth	3000m (9843 ft)
Hyperbaric external test pressure	1.1 x hydrostatic pressure
Design lifetime	25 years
Communication interface	Ethernet and DSL communications or Power line
Communication	Automatically switch between DSL, Ethernet or Power line, fibre optic communication is optional
Power supply	200 - 600 VAC
Subsea connection interface	Any major ROV connector type (ODI, Tronic, Seacon)
Environmental qualification (ISO 13628-6)	Temperature - Operating: -18 °C to +40°C, Storage: -18°C to +50°C
	Vibration - Sinusoidal vibration sweeps in 3-axes 5 - 150 Hz (operating), 5 - 25 Hz +/- 2mm, 25-150Hz 5g rms, Random vibration endurance test in worst-case axis, 20 - 2000 Hz, 6g rms (operating)
	Shock - 10g peak, 11ms half-sine pulse
Input	<ul style="list-style-type: none"> <li>• Single or redundant supply (DSL + power)</li> <li>• 2 x DSL, up to 15 Mbit/s</li> <li>• 2 x AC w/power-line communication as backup up to 1.3Mbit/s</li> <li>• Optional fibre-optic communication to surface (up to 120 km)</li> <li>• Can be customised</li> </ul>
Output	<ul style="list-style-type: none"> <li>• 6 x 230 VAC/6 x 27 VDC (with power management)</li> <li>• SIIS Level 3 - up to 6 x Ethernet/6 x DSL</li> <li>• SIIS Level 2 - CANOpen</li> <li>• SIIS Level 1 - 4-20 mA</li> <li>• Communication output can be customised</li> <li>• Can be daisy-chained to another OCH</li> <li>• Can be installed directly on seabed</li> </ul>